

## **Corporate ESG Profile on Performance: Evidence from Indonesian Insurance Industry**

December 2018

### **Abstract**

Sustainable growth is necessary, and even a key, to every business, including financial institutions such as an insurance company. Many financial institutions conducting irresponsible practices, such as exploiting market inefficiency, have been faced with severe consequences. Evidence from some studies conclude that insurance firms need to adopt a socially responsible approach to conducting business as it may lead to better financial performance. Designing and proposing sustainable insurance programs to insurance companies that run their businesses in Indonesia have been one of the insurers' approaches to creating more stable and certain industry climate since ESG issues have become prominent discussion among developed and developing countries. In our study, we attempt to construct the ESG profile by integrating three components: (1) the firm's level of understanding of ESG principles, (2) the way or manner by which the firm is integrating the ESG, and (3) the firm's paradigm on ESG integration. This study explores and examines the current state of sustainable insurance development in Indonesia, portrayed by insurance firms' knowledge, readiness, and potential in developing sustainable insurance. By performing two techniques of multivariate analysis: SEM analysis and econometric analysis, the SME results conclude that the insurer's knowledge and current development in sustainable insurance products have a positive effect on the insurance firm's willingness to develop sustainable insurance products in the future, while our regression analysis provides evidence that an insurance company's level of understanding of sustainable finance principles is positively and significantly related to firm performance. Accordingly, the main recommendation of this study is broadening the horizon of ESG risk knowledge of the potential clients of sustainable insurance products could help insurance companies market their sustainable products more effectively and efficiently.

JEL Classifications: G22

Keywords: ESG Profile, Firm Performance, Insurance Industry

---

Corresponding author: Istiana Maftuchah (istiana.maftuchah@ojk.go.id).

The findings and interpretations expressed in this paper are entirely those of the authors and do not represent the views of Indonesia Financial Services Authority (OJK). All remaining errors and omissions rest with the authors.

## I. Background

Sustainable insurance can be implemented by insurance firms by: (1) embedding the ESG (environmental-social-governance) principle in decision-making, (2) building a framework that enables an insurer to identify and evaluate ESG factors, and (3) implementing the framework in company operations. Thus, the sustainable insurance concept is an amalgamation of the green insurance and micro-insurance insurance concepts. The landmark of sustainable finance era was established through the passage of Indonesian Financial Services Authority (*Otoritas Jasa Keuangan*, OJK) Regulation concerning the Implementation of Sustainable Finance by Financial Institutions, which stipulates that financial sectors/institutions have to implement Sustainable Finance to support sustainable economic growth, social justice and environmental quality improvement. OJK has launched POJK No.51/POJK.03/2017 concerning the Application of Sustainable Finance for Financial Service Institutions, Issuers, and Public Companies on July 2017.

There has been some literature that investigated the causality between ESG profile and financial performance. El Ghouli et al. (2011) and Gregory et al. (2014) argue that a strong ESG profile has higher valuation. El Ghouli et al. (2011) show that ESG investments in employee relation, environmental policy, and product strategy contribute to lowering the firm's cost of equity. Meanwhile, Gregory et al. (2014) also find evidence that high ESG firms tend to have a higher expected growth and a lower cost of equity.

As a result, insurance firms need to adopt a socially responsible approach to conducting business as it may lead to better financial performance. ESG investing is faced with an agency problem in its implementation (UNEP FI and WBCSD, 2010). Many of the investors have a narrow view on the ESG factors. In fact, they tend to be more concerned about ESG factors that might affect the company reputation, thereby constraining a company's executives to manage the ESG factors. Hence, empirical studies on ESG investing are needed to raise investor awareness. UNEP FI and WBCSD's (2010) report also finds evidence that most of the executives agreed to the notion that ESG factors affected their companies' performances in a long run.

As an insurance firm's business environment becomes more demanding and complex, all intertwined financial industry stakeholders must pay more attention and be responsive to the circumstances. Designing and proposing sustainable insurance programs to insurance companies that run their businesses in Indonesia have been one of the OJK's approaches to creating more stable and certain industry climate since environmental issues have become prominent discussion among developed and developing countries. Currently, Indonesian insurance firms have offered three types of sustainable insurance products: (1) agriculture, (2) micro-insurance, and (3) weather index. Therefore, Indonesian insurers still have a big room for maneuver in product offering. Geographically, Indonesia is relatively prone to catastrophe incidents, such as earthquakes, flood, etc. Natural disaster is indeed a serious concern for economic sustainability, and it could certainly drive businesses out of operations.

Hence, to implement sustainable finance we have to identify what kinds of products insurers have offered at the moment. In this study, we investigate whether Indonesian insurance firms have the capability of developing sustainable insurance products, and in what state the product development has been reached. Our study seeks to find insurer's awareness on the principles of sustainable finance mentioned in. We harness the insurer's awareness as a component for constructing the ESG profile.

Accordingly, this study purports to (1) analyze Indonesian insurance firms' level of understanding of sustainable finance principles in insurance, (2) discuss the current circumstances of sustainable insurance implementation by Indonesian insurance companies, (3) evaluate the potentials of sustainable insurance development in Indonesia, and (4)

examine the relationship between sustainable insurance profile and financial performance. We conduct survey and analyze whether insurance companies in Indonesia are interested in developing sustainable insurance products. We are also interested in documenting what types of products they willing to create. Participants' responses depict insurance firms' paradigm on the ESG integration.

The remainder of this paper is structured as follows. Section 2 discusses theoretical foundation of this study. Section 3 describes our research methodology. Section 4 presents our empirical findings. Eventually, Section 5 concludes the paper.

## **II. Theoretical Foundation: Sustainable Insurance**

Insurance is playing an important role, both in its function in enabling the mutualization of risk and as an institutional investor. By reducing uncertainty and the impacts of big losses, this industry could encourage new investments and innovation, incentivize risk reduction, and enable economic recovery after a disaster. The UNEP FI (United Nations Finance Initiative) describes sustainable insurance as a strategic approach wherein all activities in the insurance industry chain, including interactions with stakeholders, are conducted responsibly and is forward looking through identifying, assessing, managing, and controlling risk and opportunities associated with environmental, social, and governance issues ("ESG Issues": environmental, social and governance).<sup>1</sup> The aim of sustainable insurance is to minimize risk, develop innovative solutions, increasing business performance, and contributing to the longevity of the environment, society, and the economy.

What is meant by "sustainable" in sustainable insurance is that the insurance company conducts its business activities whilst considering the environmental aspects, social circumstances, and financial dimensions to ensure its longevity in the coming future. The rising concern regarding environmental, social, and governance issues pose risks as well as creating new opportunities in the insurance sector. The insurance sector has a great potential to play a role in the economic realization and sustainable social growth.

Risk identification and measurement are salient challenges to insurance firms. Meanwhile, climate change and disasters are the major risk sources in Indonesia. According to the National Disaster Relief Agency (BNPB), Indonesia suffered 2,341 incidents of disasters during 2017 (Riswandi, 2018). Accordingly, insurance products that insure climate change have a high demand potential in Indonesia. This implies that insurer's capacity to identify and measure climate risk may significantly lead to stronger firm performance.

As alluded to above, product innovation is one way for an insurer to implement sustainable insurance. Sustainable products are created by integrating economic, social, and governance (ESG) factors in their product features. Hence, the more relevant the product features with ESG issues, the better the insurer implementing sustainable insurance will be. We utilize the United Nations Environment Program Finance Initiative's (UNEP FI) publication and the Environmental-based Business Activities (*Kegiatan Usaha Berbasis Lingkungan*, KUBL) as references to identify the ESG issues.

Wang and Zhi's (2016) study shows that there are six potential products that an insurer can offer to implement sustainable finance: (1) environmental fund and biodiversity fund, debt-for-environment swaps, forestry securitization, weather derivatives, nature-linked securities, and green investment fund. Sloggett (2016) documents that ESG factors could affect a firm's valuation through various channels. He examined the ESG factors alongside other valuation drivers. Although the ESG factors are generally qualitative in nature,

---

<sup>1</sup> Prinsip Investasi Berkelanjutan UNEP FI.

investors have increasingly quantified and integrated the ESG factors into financial forecasting and firm valuation models.

The regulation POJK No.51/POJK.03/2017 mandates that the Principles for Sustainable Finance (PSF) be the guidelines for the implementation of sustainable finance and include the establishment of compulsory environmental and social management systems and associated reporting in the entire financial services sector including publicly listed issuers and companies with a gradual application for each financial service institution including insurance firms. In implementing the OJK regulation on Sustainable Finance, OJK encourages financial services sector actors in creating, developing sustainable product innovations, and supporting financing of production activities that can create economic growth, social justice and environmental quality improvement. Based on this POJK regarding the Implementation of Sustainable Financing for Financial Services Institutions, Issuers, and Public Companies, the insurance products which are included in the environmentally friendly and social welfare products include green insurance, insurance covering environmental damage, building insurance, agricultural insurance and premium discounting for green projects.

Issues which are a main concern of sustainable insurance include:

- Green issues

Human activities are predicted to be one of the leading causes of global warming. The rapid growth of the industrial sector and various human activities increases the quantity of CO<sub>2</sub> and other emissions in the atmosphere. According to the United Nation's 2015 Global Assessment Report on Disaster Risk Reduction report<sup>2</sup>, as many as 25.4 million people experience loss due to natural disasters or other circumstances related to climate change each year (after 2007). Losses due to damage/loss of assets due to these events are predicted to reach 250-350 billion dollars each year. The occurrence of natural disasters or other events related to climate change may distort the market and even create the disappearance of people's livelihood. The poor are set to be the party with the greatest loss when natural disasters strike, as the total of their assets are usually only enough to fulfil daily needs with no savings to cover for emergencies such as disasters.

Insurance is one of the ways risk management may facilitate the adaptation process linked to climate change. Insurance may aid in risk reduction that may occur due to climate change. Moreover, it guarantees any damages done to the environment due to climate change or even human activities. Drastic climate change due to global warming and the continued rapid growth of the industrial sector pushes insurance companies to develop insurance products which heeds to risks arising due to climate change as well as encouraging green activities and green behaviors. This notion underlies the "green insurance" concept. Progress in green insurance is meant to incite innovations in emission reductions and resolving and mitigating global climate change.

Green insurance usually includes insurance with a variety of premiums with base characteristics/behaviors that are relevant to environmental conditions, as well as products aimed to compel people to engage in green activities and sustainability. Green insurance products are insurance products which ensures the planning, production and implementation of environmentally friendly products and public health. For example, insurance companies in developed countries offering green insurance products use incentives for the insured to use renewable energy and becoming more energy efficient. Furthermore, insurance companies also aid closing

---

<sup>2</sup> <http://www.cgap.org/blog/disaster-risk-insurance-promote-resilience>, Accessed on 27 June 2018.

costs in the development of renewable energy infrastructure. In addition, green insurance also offers to guarantee the consequences of environmental damage that will be caused by an agency/business and/or guarantee the victims of environmental damage.

- Social issues

Prevalent social issues which become a concern of the insurance industry amongst others include, financial inclusion, human rights violations, the increased human-caused health risks, and the aging population. The level of awareness for insurance of the Indonesian society is still considerably low when compared to other nations. Insurance is still considered to be a tertiary need, wherein it is very closely related to a person's level of income and education. Therefore, insurance products which are more affordable for the lower middle class, such as farmers and fishermen, need to be developed. The Indonesia's Financial Services Authority defines micro-insurance products as insurance products which are designed to give protection from financial risks that are being faced by those with low income.

Micro-insurance is a method to channel insurance to the poor through micro-financial concepts and is a solution for social and economic vulnerability as well as financial inclusion. In the Grand Design of the Indonesian Micro-insurance<sup>3</sup>, low income citizens are defined as citizens with an income per month of less than Rp2,500,000. Micro-insurance products will thus provide protection for people with low income from the various risks that may threaten the survival of poor households.

- Governance issue

The issue of governance which have become the concern of the insurance sector to actualize sustainable insurance include the regulations which are implemented within the insurance company, monitoring of processes, alignment of interests with the stake holders, the values of the organization, code of ethics, business principles, as well as the transparency of the company. Good corporate governance for insurance companies is to have a set structure and processes which are used and applied by each component of the insurance company to increase the achievement of the business goals and optimizing the insurance company values for all stakeholders<sup>4</sup>. The implementation of good corporate governance can achieve sustainability for insurance companies.

### III. Research Methods

This research employs a positivism approach as it includes the confirmatory verification of different experiences rather than an intuitive approach (Gefen et al, 2000). This research is essentially a quantitative exploratory study. Another part of this study is descriptive in nature, analyzing Indonesian insurance firms' level of understanding of ESG principles, discussing the current circumstances of ESG implementation by Indonesian insurance firms, and evaluating the potentials for sustainable insurance development in Indonesia.

To observe an insurer's perception toward ESG and sustainable insurance issues, a quantitative method is utilized for measurement. Since mere quantitative statistics will not be able to address the whole issues, this research harnesses an array of approaches. Data were collected through a questionnaire distributed to top management responsible for green product development and/or investment in the Indonesian insurance companies from mid July

---

<sup>3</sup> Tim Pengembangan Asuransi Mikro Otoritas Jasa Keuangan, 2017, "Grand Design Pengembangan Asuransi Mikro Indonesia", hal. 4.

<sup>4</sup> POJK No. 73/POJK.05/2016 tentang Tata Kelola Perusahaan yang Baik bagi Perusahaan Perasuransian

to mid September 2018. Sample firms in this study are all Indonesian insurance companies that sell general (property and casualty) insurance products. Our sample set consists of general insurance firms, with a total sample of 44 companies.

Indonesian insurance firms' level of understanding is measured through respondents' feedback on part one of the questionnaire. We apply the descriptive statistics approach to analyzing data and presenting results. It is conjectured that insurance firms that have implemented the sustainable insurance principles are more inclined to show a greater understanding of ESG principles. The current circumstances of ESG implementation by Indonesian insurance firms are depicted by the survey participants' responses in the second part of the questionnaire. We also make use of descriptive statistics to elaborate on the data. Insurance firms that have implemented sustainable principles are more likely to have a greater level of fitness.

Quantitative research method that consists of multivariate SEM model and regression analysis attempts to acquire a precise measurement of something, whose main purpose is to examine the causalities among the variables provided in a questionnaire (Cooper and Schindler, 2014). In our study, the questionnaire set is comprised of five different parts, with each part consisting of a series of items. Questions listed in the questionnaire are both open and closed questions. Respondents in this research are all Indonesian insurance companies' representatives. After the participants have responded to our set of questionnaire, we analyze the data using econometrics and multivariate analysis techniques.

### III.1. Research Framework and Rationale

A rationale of our research framework is the association between knowledge and organizational learning in Nonaka's<sup>5</sup> (1994) discussion on the interaction between tacit and explicit knowledge and its subsequent spiraling through different organizational levels. Knowledge creation is focused on the building of both tacit and explicit knowledge and, more importantly, on the interconnectedness between these two aspects of knowledge through internalization and externalization (see Figure 1).

**Figure 1.** Nonaka's (1994) Spiral of Organizational Knowledge Creation

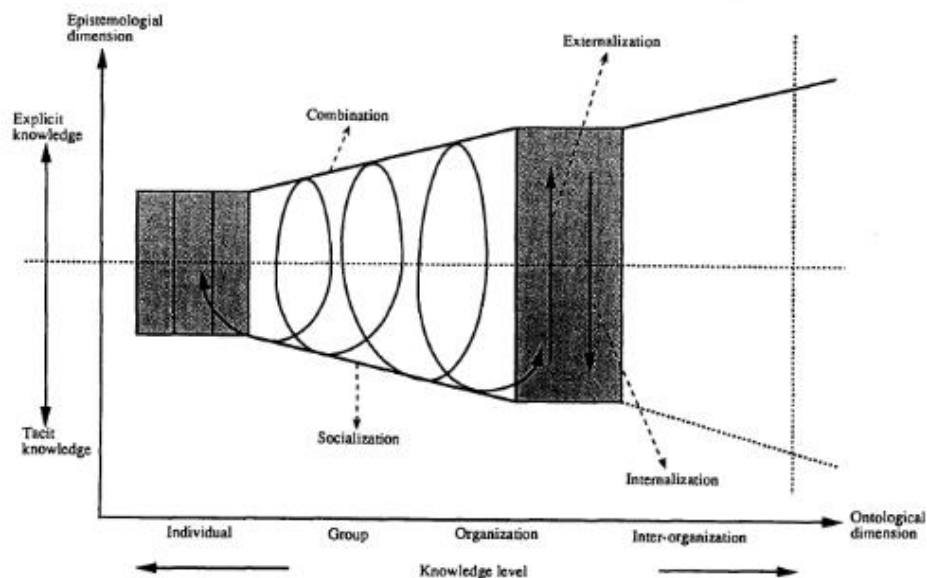

<sup>5</sup> A Dynamic Theory of Organizational Knowledge Creation, Nonaka, Ikujiro (1994), *Organization Science*, Vol. 5, No. 1 (Feb., 1994), pp. 14-37

Ringer et al.<sup>6</sup> (2016) in the 49<sup>th</sup> CIRP Conference on Manufacturing Systems (CIRP-CMS, 2016) reveal that the competitive pressure among product manufacturing companies is steadily increasing. Customers continuously demand for enhanced quality and product performance, added functionality, lower prices, and a higher speed of innovation. To survive in today's rapidly changing business environment, firms must develop more desirable products ahead concerning sustainability and ESG issues. Change is a continuous process for any organization, and the environment of change acceptance is necessary for a successful implementation of total quality management (Haffar et al., 2013; Weeks et al., 1995). Haffar et al.'s (2013) findings indicate that organizations should be focused on individual change readiness (ICR) to adopt changes in already developed processes/products. For this study, insurance firms in Indonesia differ one from another where they have a unique ICR nature that becomes a mediating variable between the Level of Insurer's Understanding of ESG Issues and the Level of Sustainable Insurance Product Development.

Another rationale of our research framework is derived from the Theory of Planned Behavior (TPB). As in the original theory of reasoned action, a central factor in the TPB is an individual's intention to perform given behavior<sup>7</sup> (Ajzen, 1991). Intention is assumed to capture motivational factors that affect behavior. It is an indication of how hard people are willing to strive and how much effort they are planning to exert in order to perform the behavior (see Figure 2). As a general rule, the stronger the intention to engage in behavior, the more likely the higher performance would be. It should be clear, however, that a behavioral intention can find expression in behavior only if the behavior in question is under a volitional control, i.e., if the person could decide at will to perform or not perform the behavior. Although some behavior might in fact meet this requirement, the performance is dependent upon non-motivational factors, such as the availability of requisite opportunities and resources (e.g., time, money, skills, cooperations; see Ajzen, 1985 for discussion). Overall, these factors represent people's actual control over the behavior. To the level that a person intends to perform the behavior and has the required opportunities and resources, he or she would succeed in doing so.

**Figure 2.** Theory of Planned Behavior

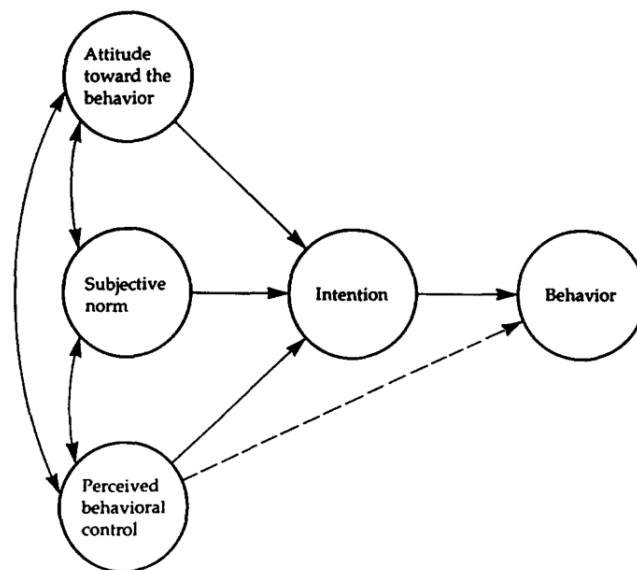

<sup>6</sup> Learning and knowledge systems in product development, *Procedia CIRP* 57 (2016), 49-54

<sup>7</sup> The Theory of Planned Behavior, Ajzen, Icek (1991), *ORGANIZATIONAL BEHAVIOR AND HUMAN DECISION PROCESSES* 50, 179-211

The first objective of our research is to analyze Indonesian insurance firms' level of understanding of ESG principles from the perspectives of top executives of insurance firms or institutions in Indonesia. Corresponding with the purposes of each part of the questionnaire and the target respondents, we attempt to capture the motivational factors that influence behavior and the willingness of respondents to comply with sustainable insurance and ESG issues. We utilize TPB as the main theoretical standpoint since it is an appropriate concept to capture the intention of respondents. Accordingly, in this study, we investigate whether Indonesian insurance firms have the capability of developing sustainable insurance products, and in what state the product development has been reached. Figure 3 shows the main framework of our structural equation model. The survey instrument is designed to achieve the research objectives established previously.

**Figure 3.** Research Framework for the Study's Structural Equation Model

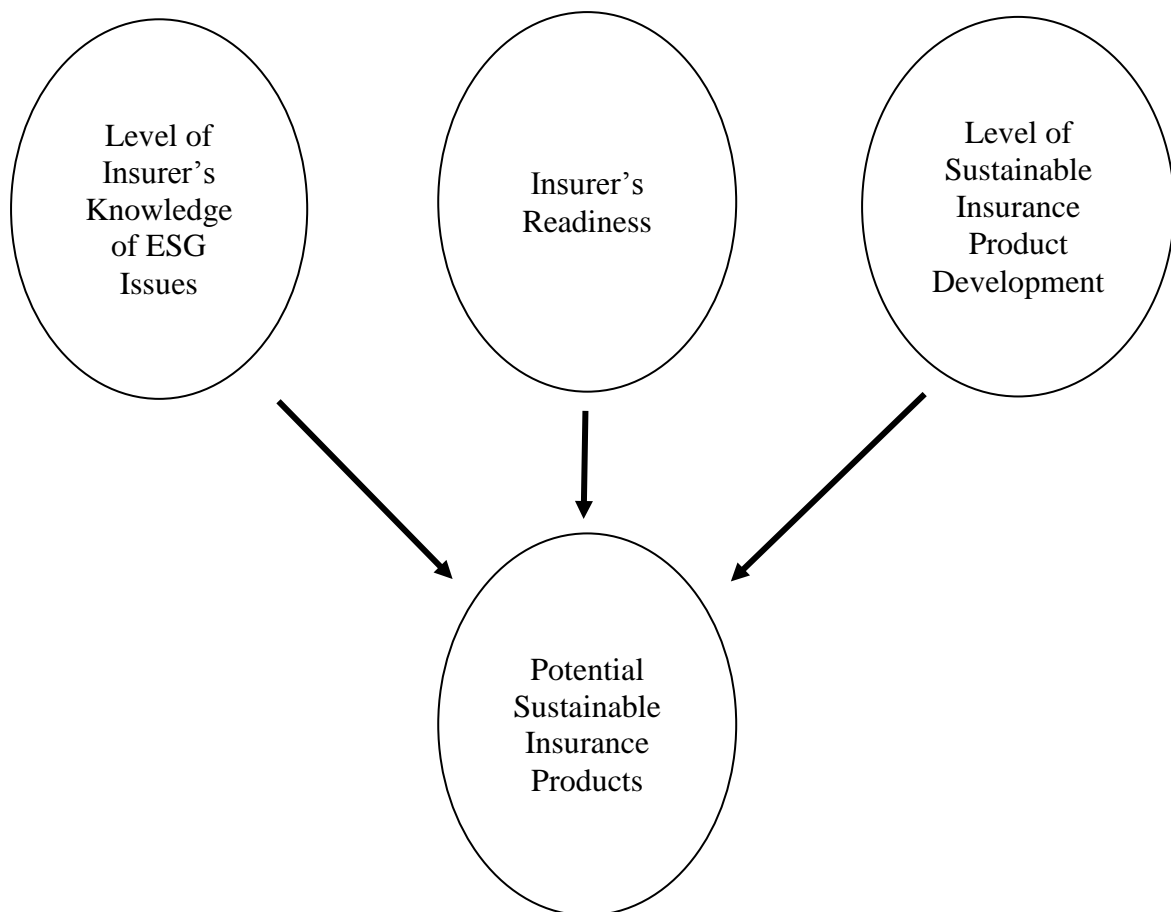

### III.2. Research Model: SEM Path Analysis

Structural equation modeling (SEM) is an advanced multivariate statistical process with which a researcher can estimate simultaneously a system of hypothesized relationships among latent variables whether these associations are consistent with an obtained sample of data (Bollen, 1989). This method is preferred by the researcher because it estimates the multiple and interrelated dependence in a single analysis.



Latent variables are theoretical concepts that unite phenomena under a single term, e.g., knowledge of ESG, readiness of ESG implementation, product development, and potential product development. Latent variables are not measured directly but can be expressed in terms of one or more directly measurable variables called indicators. Many structural equation models are represented by path diagrams, with which researchers describe their theories about the relationships among variables.

This study analyses the correlation matrix of four variables from 44 Indonesia's insurance companies using methods of structural equation modelling. The SEM path model could visually display the hypotheses and the relationships among latent variables. Figure 3 shows a simple path model intertwined with this research. We hypothesize and test a conceptual model to characterize the interdependencies between four latent variables. In particular, we are interested in measuring the direct, indirect, and total effects of four latent variables.

**Figure 4.** SEM Path Analysis Related to This Research

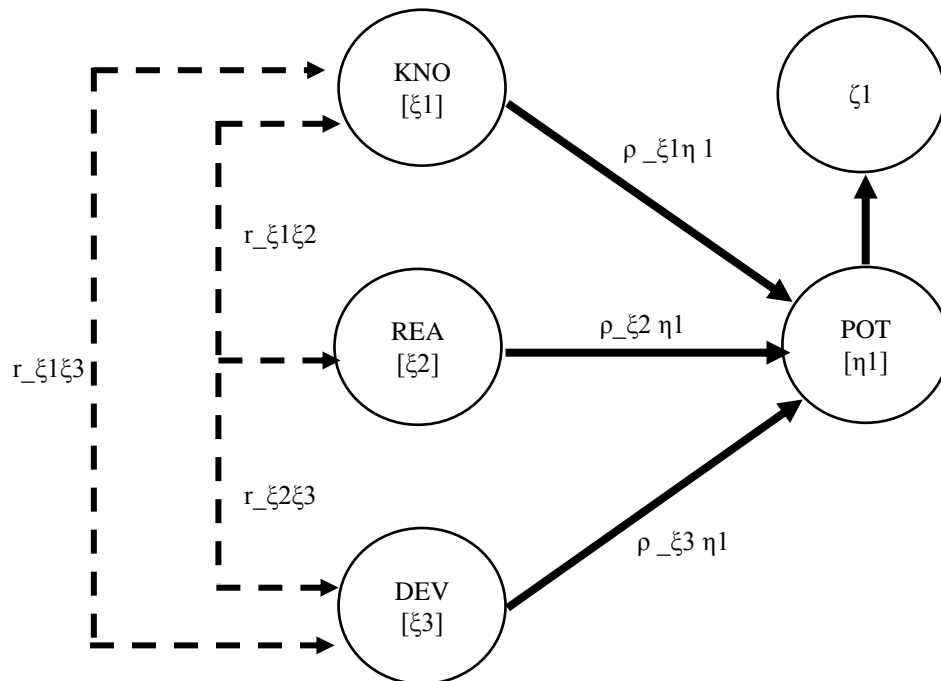

where:

- KNO = the first exogenous variable that represents the level of insurer's knowledge of ESG issues.
- REA = the second exogenous latent variable that represents insurer's readiness.
- DEV = the third exogenous latent variable that is a proxy for the level of sustainable insurance product development.
- POT = the endogenous latent variable that represents potential sustainable insurance products.
- $r_{\xi1\xi2}$  = coefficient of correlation between [KNO] and [REA].
- $r_{\xi1\xi3}$  = coefficient of correlation between [KNO] and [DEV].
- $r_{\xi2\xi3}$  = coefficient correlation between [REA] and [DEV].
- $\rho_{\xi1\eta1}$  = path coefficient of [KNO] and [POT].
- $\rho_{\xi2\eta1}$  = path coefficient of [REA] and [POT].
- $\rho_{\xi3\eta1}$  = path coefficient of [DEV] and [POT].
- $\zeta1$  = error term of path model.

The relationships discussed above can be formally stated as follows:

$$\eta_i = \gamma_1 \xi_{1i} + \gamma_2 \xi_{2i} + \gamma_3 \xi_{3i} + \varepsilon_i$$

where:

- $\eta_i$  = the endogenous latent variable that represents potential sustainable insurance products.
- $\xi_{1i}$  = the first exogenous variable that represents the level of insurer's knowledge of ESG issues.
- $\xi_{2i}$  = the second exogenous latent variable that represents insurer's readiness.
- $\xi_{3i}$  = the third exogenous latent variable that represents the level of sustainable insurance product development.
- $\gamma_1, \gamma_2, \gamma_3$  = regression coefficients on exogenous latent variables.
- $\varepsilon_i$  = error term.

Four latent variables are employed in this research. The complete list and descriptions of the latent variables are presented in Table 1. All latent variables in this study are: (1) Level of Insurer's Knowledge of ESG Issues [KNO], (2) Insurer's Readiness [REA], (3) Level of Sustainable insurance Product Development [DEV], and (4) Potential Sustainable insurance Products [POT]. The independent latent variables in this study are [KNO], [REA], and [DEV]. [KNO] variable is the first latent independent variable that represents the insurer's understanding of the adoption level of Eight Principles of Sustainable Finance in the insurer's business practice. This variable is created to explore an insurance firm's perspective on the importance of complying with eight sustainable finance principles written in Chapter 2 Verse 2 of OJK Regulation No. 51/POJK.03/2017. The process of finding relationships among variables within the framework of this study follows the order of the parts of questions listed in the questionnaire. Brief descriptions of all the variables are provided in Table 1.

**Table 1.** Latent Variable Definition

No.	Variable	Description	Definition
1.	KNO	First exogenous variable that represents the level of insurer's knowledge of ESG issues	Insurer's understanding of the adoption level of Eight Principles of Sustainable Finance in the insurer's business practice
2.	REA	Second exogenous variable that represents insurer's readiness	Insurer's level of readiness for Sustainable Finance implementation in its firm
3.	DEV	Third exogenous variable that represents the level of sustainable insurance product development	Development of insurance products based on the Categories of Environmental-Based Business Activities (KUBL) and the integration of Environmental, Social, and Governance (ESG) components in the company's business practice
4.	POT	The endogenous variable that represents potential sustainable insurance products	Some potential Sustainable Insurance Products that could be developed by Indonesian insurance firms

To measure the latent variables, this research uses a five-point Likert scale, with “1” being strongly disagree and “5” being strongly agree. There are 56 indicators utilized in a single survey questionnaire. Table 2 shows a detailed quantity breakdown for each latent variable.

**Table 2.** Detailed Indicators Quantity

<b>Indicator</b>	<b>Description</b>	<b>Quantity</b>
kno_x	Reflective indicator for KNO variable	11
rea_x	Reflective indicator for REA variable	15
dev_x	Reflective indicator for DEV variable	19
pot_y	Reflective indicator for POT variable	11
<b>Total</b>		<b>56</b>

There is no exact rule as to how many indicators are required for each latent variable. The general rule is the more the better, and avoid a single indicator. However, we must take into account possible human errors and disengagement on account of too many questions presented in a single survey session. Therefore, we reckon that 56 survey questions are considered a robust number from both the researchers’ and the respondents’ perspectives.

Data are derived from the questionnaire set distributed to all directors of insurance companies in Indonesia. For the SEM test purposes, there is a minimum required sample size to detect minimum  $R^2$  values of 0.10, 0.25, 0.50, and 0.75 for significance levels of 1%, 5%, and 10%, respectively. In social sciences, a 5% significance level is considered common, therefore this research uses a 5% confidence level. Estimation of a model can be performed with various PLS software packages. Many researchers use Smart-PLS since it is well known and considered effective. There are three key results provided upon computation: (1) the outer loadings for reflective measurement (or weights for formative measurement) for the measurement model, (2) the path coefficients for the structural model relationships, and (3)  $R^2$  values of the latent endogenous variables. Nevertheless, the three key findings need to be checked by this study for reliability and validity. To determine how well the theory fits the data, this study conducts various examinations since there is no single goodness-of-fit criterion available in PLS-SEM

### **III.3. Research Model: Econometric Analysis**

This study also utilizes the econometric approach to analyzing the impacts of sustainable insurance and ESG practices on Indonesian insurance firms or institutions. The econometric technique employed is the linear regression model, which is harnessed to predict a dependent variable given one or more independent variables. It is considered either a generalization of multiple linear regression or a generalization of binomial logistic regression.

The relationship between sustainable conduct and firm performance has yet to be widely investigated on the insurance industry. In fact, there is a limited number of studies on sustainable insurance. Prior research on insurance firms suggests that the financial performance of insurers could be measured in a more specific way as shown in Table 3.

**Table 3.** Summary of Prior Findings of Firm Performance in the Insurance Industry

<b>Variable</b>	<b>Description</b>	<b>Referred Articles</b>
In(NP)	Natural logarithm of <i>Net Profit</i>	<ol style="list-style-type: none"> <li>1. Calandro and Lane (2002), The insurance performance measure: Bringing value to the insurance industry, <i>Journal of Applied Corporate Finance</i></li> <li>2. Orlitzky, Schmidt, and Reynes (2003), Corporate social and financial performance: A meta-analysis, <i>Organization Studies</i></li> <li>3. Allouche, Laroche, and Eska (2005), A meta-analytical investigation of the relationship between corporate social and financial performance, <i>Revue de Gestion des Ressources Humaines</i></li> </ol>
In(US)	Natural logarithm of <i>Underwriting Surplus</i>	<ol style="list-style-type: none"> <li>1. Calandro and Lane (2003), The insurance performance measure: Assembling the property and casualty profitability puzzle, <i>Management Journal</i></li> <li>2. Calandro and Flynn (2004), Insights from research premium growth, underwriting return and segment analysis, <i>Measuring Business Excellence</i></li> <li>3. Author: Urrutia (1987), Financial pricing models and competitive underwriting returns for the insurance industry, <i>Economic Letters</i></li> </ol>
In(PI)	Natural logarithm of <i>Premium Income</i>	<ol style="list-style-type: none"> <li>1. Calandro and Lane (2002), The insurance performance measure: Bringing value to the insurance industry, <i>Journal of Applied Corporate Finance</i></li> <li>2. Orlitzky, Schmidt, and Reynes (2003), Corporate social and financial performance: A meta-analysis, <i>Organization Studies</i></li> <li>3. Allouche, Laroche, and Eska (2005), A meta-analytical investigation of the relationship between corporate social and financial performance, <i>Revue de Gestion des Ressources Humaines</i></li> </ol>
In(CI)	Natural logarithm of <i>Claims Incurred</i>	<ol style="list-style-type: none"> <li>1. Eling and Jia (2018), Business failure, efficiency, and volatility: Evidence from the European insurance industry, <i>International Review of Financial Analysis</i></li> <li>2. Garrido, Genest, dan Schulz (2016), Generalized linear models for dependent frequency and severity of insurance claims, <i>Insurance: Mathematics and Economics</i></li> <li>3. Caporale, Cerrato, and Zhang (2017), Analysing the determinants of insolvency risk for general insurance firms in the U.K., <i>Journal of Banking and Finance</i></li> </ol>

**A. Dependent Variables of this Study**

For econometric analysis, this study has four dependent variables that can represent firm's performance. They are **Net Profit**, **Premium Income**, **Underwriting Surplus**, and

**Claims Incurred.** The purpose of creating the four variables as the dependent variables is to investigate whether the corporate ESG's profile of insurers have any effect on firm's performance.

## B. Independent Variables of this Study

There are seven independent variables that we employ in this study: (1) average score of insurer's level of understanding of sustainable finance principles, (2) average score of insurer's readiness, (3) average score of insurer's current level of sustainable insurance product development, (4) average score of insurer's potential level of sustainable insurance product development, (5) number of sustainable insurance products an insurance firm is going to develop, (6) number of implemented principles of sustainable finance by an insurance firm, and (7) number of implemented sustainable finance programs by an insurance firm. Those data are collected from the information provided by respondents in the questionnaire. We also use four control variables obtained from insurance firms' reports to the OJK. The control variables are insurer's market share, insurer's liabilities, insurer's total asset, and insurer's total equity.

### Research Econometric Model:

$$(1) \text{Log}(NP_i) = \alpha + \beta_1 KNO_i + \beta_2 REA_i + \beta_3 DEV_i + \beta_4 POT_i + \beta_5 PROD_i + \beta_6 PRIN_i + \beta_7 PROG_i + \beta_8 \text{Log}L_i/\text{Log}(TA)_i + \beta_9 MS_i/\text{Log}(TA)_i + u_i$$

$$(2) \text{Log}(US_i) = \alpha + \beta_1 KNO_i + \beta_2 REA_i + \beta_3 DEV_i + \beta_4 POT_i + \beta_5 PROD_i + \beta_6 PRIN_i + \beta_7 PROG_i + \beta_8 \text{Log}L_i/\text{Log}(TA)_i + \beta_9 MS_i/\text{Log}(TA)_i + u_i$$

$$(3) \text{Log}(PI_i) = \alpha + \beta_1 KNO_i + \beta_2 REA_i + \beta_3 DEV_i + \beta_4 POT_i + \beta_5 PROD_i + \beta_6 PRIN_i + \beta_7 PROG_i + \beta_8 \text{Log}L_i/\text{Log}(TA)_i + \beta_9 MS_i/\text{Log}(TA)_i + u_i$$

$$(4) \text{Log}(CI_i) = \alpha + \beta_1 KNO_i + \beta_2 REA_i + \beta_3 DEV_i + \beta_4 POT_i + \beta_5 PROD_i + \beta_6 PRIN_i + \beta_7 PROG_i + \beta_8 \text{Log}L_i/\text{Log}(TA)_i + \beta_9 MS_i/\text{Log}(TA)_i + u_i$$

where:

$$\begin{aligned} \beta_1, \dots, \beta_9 &= \text{Regression coefficients on independent variables;} \\ i &= 44 \text{ insurance companies} \end{aligned}$$

### Dependent variables include:

$$\begin{aligned} \text{Log}(NP_i) &= \text{Total net profit of an insurance firm (in logarithm);} \\ \text{Log}(US_i) &= \text{Total underwriting surplus of an insurance firm (in logarithm);} \\ \text{Log}(PI_i) &= \text{Total premium income of an insurance firm (in logarithm);} \\ \text{Log}(CI_i) &= \text{Total claims incurred of an insurance firm (in logarithm);} \end{aligned}$$

### Independent Variables consist of:

$$\begin{aligned} KNO_i &= \text{Average score of insurer's level of understanding of sustainable finance principles; ---- a questionnaire survey data} \\ REA_i &= \text{Average score of insurer's readiness; --- survey data} \\ DEV_i &= \text{Average score of insurer's current level of sustainable insurance product development; ----- a questionnaire survey data} \end{aligned}$$

<b><math>POT_i</math></b>	= Average score of insurer's potential for sustainable insurance product development; ----- a questionnaire survey data
<b><math>PROD_i</math></b>	= Number of sustainable insurance products an insurance firm is going to develop; ----- a questionnaire survey data
<b><math>PRIN_i</math></b>	= Number of implemented principles of sustainable finance by an insurance firm; ----- a questionnaire survey data
<b><math>PROG_i</math></b>	= Number of implemented sustainable finance programs by an insurance firm; ----- a questionnaire survey data
<b><math>Log(L_i)</math></b>	= Insurance firm's total liabilities (in logarithm); --- audited Dec 2017 data
<b><math>LogTA_i</math></b>	= Insurance firm's total assets (in logarithm); ----audited Dec 2017 data
<b><math>MS_i</math></b>	= Insurance firm's market share (in percentage); --- audited Dec 2017 data
<b><math>u_i</math></b>	= Error term.

## IV. Results and Discussion

### IV.1. Respondent Information

This section elaborates on general information about respondents classified by respondent position and scale category. Total respondents in this research are 44 people, comprised of 15 persons as directors (34 percent) and 29 persons as others (66 percent). Predicated on the company scale classification, i.e., based on total assets owned, the majority of companies are small-scale insurance companies with total assets of less than Rp2 trillion (29 respondents or 66 percent). In the second place, there are 69 small medium-sized companies (20 percent). Subsequently, there are four respondents (11 percent) classified as big firms, and one respondent (2 percent) as medium-sized companies.

### IV.2. Descriptive Statistics

The descriptive statistics presents detailed information on the questionnaire contents, specifically for four latent variables of this study. They are:

#### A. Knowledge Comprehension Level of Sustainable Finance Principles [KNO]

In this part, we explore the insurer's comprehension on the adoption level of Eight Sustainable Finance Principles in the insurer's business practice. This variable is created to explore an insurance firm's perspective on the importance of complying with eight sustainable finance principles stated in OJK Regulation No . 51/POJK.03/2017. This variable consists of 11 main questions regarded as [KNO] indicators.

Most of the insurers in our analysis have responded that 91% of them have been implementing the Principles of Responsible Investment [B12.1], 75% of them Principles of Sustainable Business Strategy and Practices [B12.2], 86% of them Risk Management Principles [q.B12.3], 91% of them Governance Principles [B12.4], 80% of them Comprehensive Reporting Principles [B12.5], 48% of them Principles of Equitable Access and Territoriality [B12.6], 45% of them Principles of Developing Economic Sectors for Sustainability Priorities [B12.7], and 55% of them Principles of Coordination and Collaboration among Corporate Institutions [B12.8].

## **B. Level of Readiness for Sustainable Finance Implementation in Insurance Companies [REA]**

In this section, we document the Level of Readiness for Sustainable Finance Implementation in Insurance Companies. This variable purports to analyze insurer's perception on the priority programs of Sustainable Finance that must be implemented by an insurance firm at the time of full implementation of Sustainable Finance (Article 7 of OJK Regulation Number

51/POJK.03/2017). This variable consists of 15 main questions, labelled as [REA] indicators. The three priorities are: product innovation, capacity building, and organizational adjustment.

We identify current business activities and strategies that insurers have been undertaking. From our data analysis, there are only 27% of sample firms that have been developing sustainable insurance products, 52% have enhanced their internal capacities for the implementation of sustainable finance, and 50% have been conducting organizational adjustments, risk management, governance, and/or standard operating procedures that comply with the principles of sustainable finance.

We also observe the priorities of insurers toward the development of sustainable finance programs, and find that 50% of insurers prioritize organizational adjustments, risk management, governance, and/or standard operating procedures that apply the principles of sustainable finance, 36% of insurance firms have increased their internal capacities for the implementation of sustainable finance, and only 14% of companies are prioritizing sustainable insurance product development.

## **C. Perception on the Development of Insurance Products Based on the Categories of Environmental-Based Business Activities and the Integration of ESG Components in an Insurer's Business Practices [DEV]**

According to the guidelines for sustainable insurance, the basis of sustainable insurance implementation is to involve environmental, social, and governance (ESG) aspects in business planning, strategy, and operation. A survey has been performed to investigate the development of insurance products based on the categories of environmental-based business activities (KUBL) and the integration of environmental, social, and governance (ESG) components in a company's business practices. This variable consists of 19 main questions, labelled as [DEV] indicators

Indicators with the highest average scores are: insurance product development for disaster risk protection [DEV – D1]; accountability in making activity reports to stakeholders [DEV – D15]; transparency in submitting activity reports to stakeholders [DEV – D16]; publication of an insurance firm's development to the society through media information [DEV – D18]; and communication with stakeholders pertaining to the benefits of transparency in practice [DEV – D19]. Hence, it can be concluded that openness with regard to insurer's information to stakeholders has already been well developed by most of the insurance companies.

Most respondents reveal that selling sustainable insurance products is in accordance with the strategies and business objectives of their firms. In fact, the insurance firms are convinced that they could contribute to the society and at the same time benefit significantly from the sales of sustainable insurance products. This corresponds with the high market demand. Meanwhile, the least common reasons are government subsidy for the product development and the ease of risk calculation.

## D. Potentials of Sustainable Insurance Product Development [POT]

This section explains the findings on a survey conducted to explore the potentials of sustainable insurance product development in the future. 11 indicators are harnessed to measure how much potential the sustainable insurance products can be developed in Indonesia, labelled as [POT] indicators

. This study result from this part strongly suggests that the chance of plans or approvals to develop or provide ESG-integrated sustainable insurance products from the insurers in the future is less promising. Meanwhile, two of 11 indicators show the biggest potential to develop among all products in the implementation of sustainable finance. Eco-friendly transportation development risk protection and small business activities risk protection have such a possibility.

Subsequent indicators following the two with highest scores above are: eco-friendly products' business activities risk protection [POT – E9], green building development risk protection [POT – E10], risk protection for business activities that support sustainable management of living natural resources and land use [POT – E4], clean and renewable energy development business activities [POT – E1], risk protection for business activities that improve energy efficiency and conservation [POT – E2], risk protection for all negative impacts of climate change on business activities [POT – E8], risk protection for business activities that support conservation of land and water biodiversity [POT – E5], and risk protection for managing sustainable water and wastewater [POT – E7]. Eventually, risk protection for business activities that may cause air pollution, water and solid waste [POT – E3] is an insurance product that has the smallest potential to be developed.

### IV.3. Multivariate Analysis

#### IV.3.1 Model Evaluation

This section purports to explain whether the model is appropriate for analysis. There are two basic assumptions that should be met by the model: (1) construct validity and (2) reliability tests. In the construct validity tests, there are two major techniques that we employ to validate the questionnaire construct: (1) convergent validity and (2) discriminant validity.

#### A. Convergent Validity

Convergent validity is a method to examine the construct validity. The word *construct* describes a theoretical viewpoint to explain some phenomena (Wiersma, 2000). According to van Dalen (1973), construct usually refers to a complex concept that includes a number of interrelated factors. In this study, the convergent validity is assessed using the Communality and Average Variance Extracted (AVE). The results of these tests are depicted in Table 4 below.

**Table 4.** Average Variance Extracted (AVE) and Communality

Parameter	Variable	Coefficient	Rule of Thumb	Conclusion
Average Variance Extracted (AVE)	KNO	0.617	More than 0.5	Acceptable
	REA	0.595	More than 0.5	Acceptable
	DEV	0.491	More than 0.5	Not Acceptable
	POT	0.746	More than 0.5	Very Acceptable
Communality	KNO	0.780	More than 0.5	Very Acceptable
	REA	0.766	More than 0.5	Very Acceptable
	DEV	0.689	More than 0.5	Acceptable
	POT	0.862	More than 0.5	Very Acceptable



From Table 4 above, it could be observed that the questionnaire construct is mostly convergent, with the exception of [DEV] variable as it has an AVE coefficient below 0.5. Nevertheless, if an AVE is less than 0.5 but the composite reliability is higher than 0.6, then the convergent validity of a construct is still adequate (Fornell and Larcker, 1981).

## B. Discriminant Validity

Discriminant validity is a test to ensure that there is no significant variance among different variables that could have the same reason. The discriminant validity aims to differentiate between one construct and another in the same model. To assess the discriminant validity, two common techniques are utilized. First, according to Hair et al. (2010), if the correlations of two latent variables exceed 0.9, then they have significantly overlapping constructs. In other words, multicollinearity exists between them. Second, to assess the discriminant validity, we compare the AVE and the squared correlation between two constructs. Fornell and Larcker (1981) reveal that to check the discriminant validity, the square root of AVE is compared with the correlations involving the constructs, where the former is expected to be greater than the latter. In this study, we apply the second approach as the tool to analyze the discriminant validity. The results of the test are presented in Table 5 below.

**Table 5.** Correlations among Latent Variables with Square Roots of AVEs

	KNO	REA	DEV	POT
KNO	(0.786)	0.736	0.631	0.595
REA	0.736	(0.771)	0.558	0.409
DEV	0.631	0.558	(0.701)	0.649
POT	0.595	0.409	0.649	(0.864)

*Note: Square roots of average variances extracted (AVEs) are shown in diagonal*

From Table 5, it can be concluded that the overall construct of questionnaire is valid since the correlations among latent variables are below the square roots of AVE coefficients for all variables. Hence, the questionnaire has met the necessary conditions for further analysis.

## C. Reliability Test

To gauge the reliability of the questionnaire, we use the Cronbach's alpha and composite reliability methods as indicators to suggest as to whether the questionnaire's constructs are reliable to measure the connections among variables. The results of the tests are reported in Tables 6 and 7 below.

**Table 6.** Cronbach's Alpha

Indicator	Cronbach's Alpha	Rule of Thumb	Conclusion
KNO	0.936	More than 0.6	Acceptable
REA	0.950	More than 0.6	Acceptable
DEV	0.940	More than 0.6	Acceptable
POT	0.965	More than 0.6	Acceptable

**Table 7.** Composite Reliability

Indicator	Composite Reliability	Rule of Thumb	Conclusion
KNO	0.946	More than 0.7	Acceptable
REA	0.956	More than 0.7	Acceptable
DEV	0.947	More than 0.7	Acceptable
POT	0.970	More than 0.7	Acceptable

The findings shown in Tables 6 and 7 suggest that the questionnaire’s constructs are reliable to be used to measure the relationships among variables.

### IV.3.2. Main Analysis

Upon conducting a series of prerequisite examinations above, we perform the PLS-SEM analysis on our model. The results of the test are depicted in the following Figure 5. Figure 5 below shows evidence of the connections among latent variables conjectured in our model. The first finding is, there is a positive effect of [KNO] on [POT], with a coefficient of 0.40 significant at 1% level. This means [POT] will improve by 0.40 points when [KNO] increases by one point. Accordingly, when an insurance firm has knowledge toward sustainable insurance products, it shows a higher potential to develop sustainable insurance products in the future.

The second result is, there is a significantly positive influence (at 1% level) of [KNO] on [REA], with a coefficient of 0.74. This indicates that [REA] will increase by 0.74 points when [KNO] increases by one point, thus explaining the fact that if an insurance company has knowledge of sustainable insurance products, it will be more ready to implement sustainable finance in its business activities.

Subsequently, the coefficient on the relationship between [REA] and [POT] is positive (0.13), but it is not significant. Hence, [REA] does not affect [POT] directly. If an insurance firm is ready to implement sustainable finance in its business activities, it does not necessarily mean that the insurance company shows a potential to develop sustainable insurance products in the future.

**Figure 5.** PLS-Structural Equation Model Results

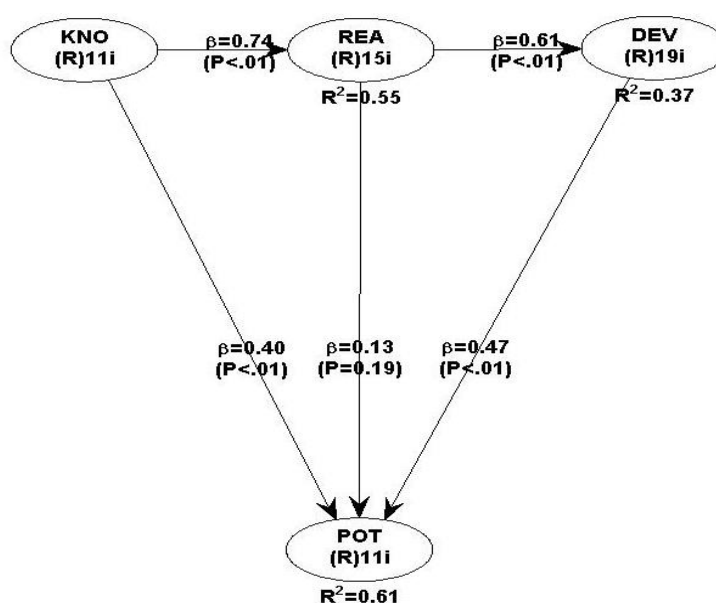

The fourth finding is, [REA] affects [DEV] positively, with a coefficient of 0.61 significant at 1% level. This finding suggests that [DEV] will increase by 0.61 points if [REA] increases by one point. Therefore, when an insurance company is ready to implement sustainable finance in its business activities, it will be more likely to develop sustainable insurance products that correspond with the environmental-based activities and ESG issues in its business practice.

Eventually, the fifth result documents that there is a positive and significant effect (at 1% level) of [DEV] on [POT], with a coefficient of 0.47. This means that [POT] will be higher by 0.47 points when [DEV] increases by one point, substantiating the conjecture that if an insurance firm has developed insurance products that are aware of the environmental-based activities and ESG issues in its business practice, the insurance company will show a higher potential to develop sustainable insurance products in the future.

#### IV.4. Econometric Analysis

##### IV.4.1 OLS Regression Results

As built and expounded in section III.3, our regression analysis is aimed at finding the relationship between an insurance firm's performance and its sustainability characteristics (including its ESG profile). We measure firm performance using four proxy variables: (1) net profit/loss, (2) underwriting surplus, (3) premium income, and (4) claim incurred. Those variables are transformed into a logarithmic form.

Meanwhile, our independent variables that proxy for an insurance company's sustainability characteristics (ESG profile) comprise seven variables: (1) the insurer's level of understanding on sustainable finance principles (KNO), (2) the insurer's readiness (REA), (3) the insurer's current level of green insurance product development (DEV), (4) the insurer's potential level of green insurance product development in the future (POT), (5) the number of sustainable insurance products the insurance firm is going to develop (PROD), (6) the number of sustainable principles the insurance firm has implemented (PRIN), (7) the number of implemented sustainable finance programs by the insurance firm (PROG).

Furthermore, we employ two variables as control: (1) the ratio of logarithm of liabilities to logarithm of total assets and (2) the ratio of market share to logarithm of total assets. Table 8 presents the regression results. We employ the heteroskedasticity-robust standard errors for all models.

**Table 8.** Multivariate Regression Analysis

Variable	ln(NP) (1)	ln(US) (2)	ln(PI) (3)	ln(CI) (4)
<b>KNO</b>	1.228* (1.76)	0.307 (0.74)	0.773* (1.68)	-0.049 (-0.11)
<b>PRIN</b>	0.050 (0.40)	0.058 (0.74)	-0.034 (-0.40)	-0.051 (-0.60)
<b>REA</b>	-0.895 (-1.47)	-0.278 (-0.73)	-0.214 (-0.70)	-0.036 (-0.09)
<b>PROG</b>	-0.115 (-0.36)	-0.068 (-0.39)	0.101 (0.46)	0.191 (1.00)
<b>DEV</b>	0.138 (0.24)	-0.202 (-0.57)	-0.281 (-0.86)	0.491 (1.29)
<b>POT</b>	-0.752 (-1.51)	0.003 (0.01)	-0.231 (-0.81)	-0.400 (-1.23)

<b>PROD</b>	0.004 (0.12)	0.012 (0.64)	0.016 (0.90)	0.000 (-0.01)
<b>RLTA</b>	14.115* (2.00)	17.15822*** (3.82)	20.33843*** (3.98)	18.75219*** (3.76)
<b>RMSTA</b>	973.740*** (5.30)	861.8567*** (7.47)	669.611*** (6.19)	970.2767*** (7.81)
<b>Intercept</b>	-3.402 (-0.46)	-3.824 (-0.82)	-9.154 (-1.67)	-6.551 (-1.26)
<b>Adj. R<sup>2</sup></b>	0.5530	0.698	0.735	0.750
<b>F-stat</b>	5.95***	12.06***	9.83***	15.00***
<b>N</b>	37	44	42	43

\*, \*\*, and \*\*\* denote significance levels at 10%, 5%, and 1%, respectively. F-stat shows the overall significance of the regression model. The omitted numbers of observations in Models (1), (3), and (4) are due to incomplete data for net profit, premium income, and claim incurred.

The regression analysis is conducted on a sample of 44 insurance firms harnessing primary and secondary data. The independent variables of KNO, REA, DEV, POT, PROD, PRIN, and PROG were collected through distributing a questionnaire set, whereas the control variables were obtained from insurance firm reports to the Indonesian Financial Services Authority (OJK). As shown in table 8, overall, our regression models exhibit sound R-squared values for a cross-sectional study. The F-statistic is strongly significant in all regression models. Hence, **the independent variables are jointly and significantly able to explain the dependent variable.**

For the significance of individual independent variables, the control variables RLTA and RMSTA have significant coefficients in all examined models. For main independent variables, in Model 1, we find that the coefficient on KNO is positively and statistically significant at 10% level, suggesting that insurance firms with a better level of understanding on sustainable finance principles would experience a stronger improvement in its net income. The finding suggests that if the level of knowledge increases by one level, then the net profit will go up by 1.23%. One of the rationales is, the insurance firms with a higher level of understanding on sustainable finance principles could measure the ESG risk more accurately.

Subsequently, we pay closer attention to firm performance attributes in Models 2, 3, and 4, i.e., underwriting surplus (US), premium income (PI), and claim incurred (CI). The regression results provide evidence that an insurance firm's ESG attributes are not significantly intertwined with the insurance firm's performance in Models 2 and 4. These findings imply that an insurance firm's sustainability characteristics (ESG profile) do not show adequate power to describe the insurance firm's underwriting surplus and claim incurred. Nevertheless, Model 3 reports that an insurer's level of understanding on sustainable finance principles has a positive and significant relation to the insurer's premium income, thereby substantiating our conjecture that an insurance company's level of knowledge of sustainable finance principles helps the firm enhance their income potential. Premium income is estimated to increase by 0.77% for every improvement score in the level of knowledge of sustainable finance principles by insurance companies.

#### IV.4.2 Heteroskedasticity Test

The heteroskedasticity check reveals that all regression models fulfill the homoskedastic assumption, where the variances of errors are stable throughout all observations. In this research, we utilize the White's test to examine the homoskedasticity assumption, and find that heteroskedasticity is not prevalent in all of our regression models.

**Table 9.** Heterokedasticity Test

<b>Model</b>	<b>Chi2-stat</b>	<b>Result</b>
Model 1	0.21	No heteroskedasticity
Model 2	1.09	No heteroskedasticity
Model 3	0.13	No heteroskedasticity
Model 4	1.92	No heteroskedasticity

#### IV.4.3 Multicollinearity Test

The Pearson Correlation Matrix in Table 10 depict the entire independent variables involved in the regression analysis. The independent variables are found to have a correlation coefficient below 0.8, corroborating the notion that none of them is strongly correlated to one another. This indicates that the regression models (1) to (4) do not suffer from the multicollinearity problem.

**Table 10.** Pearson Correlation Matrix of Independent Variables

	<b>KNO</b>	<b>PRIN</b>	<b>REA</b>	<b>PROG</b>	<b>DEV</b>	<b>POT</b>	<b>PROD</b>	<b>RLTA</b>	<b>RMSTA</b>
<b>KNO</b>	1.000								
<b>PRIN</b>	0.176	1.000							
<b>REA</b>	0.739	0.215	1.000						
<b>PROG</b>	0.444	0.584	0.317	1.000					
<b>DEV</b>	0.655	0.242	0.577	0.378	1.000				
<b>POT</b>	0.620	-0.071	0.430	0.126	0.664	1.000			
<b>PROD</b>	0.074	0.257	0.273	-0.078	0.250	0.242	1.000		
<b>RLTA</b>	-0.051	-0.207	-0.005	0.190	0.033	0.086	-0.337	1.000	
<b>RMSTA</b>	0.197	0.041	0.254	0.028	0.309	0.079	0.004	0.222	1.000

## V. Conclusion and Policy Implication

### V.1. Conclusion

This study explores and examines the current state of sustainable insurance development in Indonesia, portrayed by insurance firms' knowledge, readiness, and potential in developing sustainable insurance. We construct an instrument to measure an insurance firm's knowledge, readiness, current state of sustainable insurance products, and potential of developing sustainable insurance products in the future. We harness the OJK Regulation Number 51/POJK.03/2017 as the salient basis for indicators in our questionnaire since the development of sustainable insurance in Indonesia is trailblazed by the regulator (OJK) through its passages of regulations. Using a sample of 44 general insurance firms, we find evidence that insurance firms in Indonesia have sufficient knowledge of developing sustainable finance principles. However, the majority of respondents have yet to implement the Principles of Equitable Access and Territoriality and the Principles of Developing Economic Sectors for Sustainability Priorities.

Our results show that Indonesian insurance companies are relatively ready to implement sustainable insurance. The majority of insurance firms have held the capacity

building programs for their human capital to implement the sustainable insurance and measure the ESG risk. Simultaneously, insurance firms have aligned their organizational structures, standard operating procedures, and codes of conduct to the sustainable insurance principles. Despite the fact that insurance firms have the capacity and structure to implement the sustainable insurance, the insurers are faced with a difficulty creating and leveraging sustainable insurance products.

We also document that the sustainable insurance market is expanding rapidly from 2012 to 2014, and steadily growing as of today. It is evidenced that sustainable insurance products could be one of the vehicles for gaining market share. The underwriting ratio of sustainable insurance products is greater than one, suggesting that the product development may increase an insurance firm's financial performance.

Even though most of the insurers have adequate knowledge and the capability of implementing sustainable insurance, those insurance firms are quite reluctant to develop sustainable insurance products in the near future. The lack of insurer's interest in developing sustainable insurance products is rendered by the difficulties in risk identification and measurement. The most promising sustainable insurance products that an insurer is willing to develop in the future are micro-insurance, sharia micro-insurance, damage insurance for low emission vehicles, and damage insurance for environmentally-friendly machinery.

This research performs two techniques of multivariate analysis: (1) SEM analysis and (2) econometric analysis. The SEM results conclude that an insurer's knowledge of sustainable finance principles affects the insurance firm's readiness to implement sustainable insurance. Subsequently, the insurer's readiness affects its current level of sustainable insurance product development. Eventually, the insurer's knowledge and current development in sustainable insurance products have a positive effect on the insurance firm's willingness to develop sustainable insurance products in the future.

Meanwhile, our regression analysis provides evidence that an insurance company's level of understanding of sustainable finance principles is positively and significantly related to firm performance. Therefore, the insurer's level of knowledge of sustainable finance principles could be one of the factors that enhance its net profit and premium income. In fact, the empirical results suggest that if the level of knowledge increases by one level, then the net profit will go up by 1.23% and premium income is estimated to strengthen by 0.77%. One of the rationales is, the insurance firms with a higher level of understanding of sustainable finance principles could gauge the ESG risk more accurately.

## **V.2 Implications**

The findings of this paper offer a vast array of practical implications. First, Indonesian Financial Services Authority (OJK) should raise its campaign effort to increase insurance firms' awareness on sustainable finance principles, which would motivate insurers to develop sustainable products. Increases in sustainable insurance products in the market will contribute to the sustainable finance implementation, which is one of the pivotal agendas of the OJK in 2020. Moreover, sustainable insurance products could elevate an insurance firm's financial performance.

Second, the OJK should continuously improve the financial literacy of the potential clients of sustainable insurance products on the ESG risk. Broadening the horizon of ESG risk knowledge of the potential clients of sustainable insurance products could help insurance companies market their sustainable products more effectively and efficiently.

## References

- Arena, M. 2006. Does Insurance Market Activity Promote Economic Growth?. World Bank Policy Research Working Paper 4098.
- Asian Development Bank. 2017. Agriculture Insurance. ADB Briefs No. 77, April 2017.
- Asuransi. <https://www.ojk.go.id/id/kanal/iknb/Pages/Asuransi.aspx>.
- Bollen, K. A. 1989. Structural equations with latent variables. New York: Wiley.
- Boer, R. 2012. Asuransi Iklim Sebagai Jaminan Perlindungan Ketahanan Petani Terhadap Perubahan Iklim. Widyakarya Nasional Pangan dan Gizi 10: Pemantapan Ketahanan Pangan dan perbaikan Gizi Berbasis Kemandirian dan Kearifan Lokal. LIPI, Jakarta.
- BP Migas. 2011. Pedoman Tata Kerja Pengelolaan Asuransi BP Migas dan Kontraktor Kerja Sama No. PTK-044/BP00000/2011/S0.
- ClimateWise. 2011. ClimateWise Compendium of disaster risk transfer initiatives in the developing world.
- Copy of Circular Letter of the Financial Services Authority No. 9/SEOJK.05/2017 on Micro-insurance Products and Marketing Channels of Micro-insurance Products.
- Copy of Regulation of the Financial Services Authority No. 23/POJK.05/2015 on Insurance Products and Insurance Product Marketing.
- Departemen Penelitian dan Pengaturan Perbankan Otoritas Jasa Keuangan. 2017. Pokok-Pokok Pengaturan POJK No. 51/POJK.03/2017 tentang Penerapan Keuangan Berkelanjutan bagi Lembaga Jasa Keuangan, Emiten dan Perusahaan Publik.
- Direktorat Jenderal Anggaran. 2016. Analisis Strategi Pencapaian Efektivitas Pelaksanaan Anggaran Asuransi Pertanian dalam APBN melalui Analisis SWOT. Kajian Tematik Direktorat Anggaran Bidang Perekonomian dan Kemaritiman.
- Eccles, R. G., Ioannou, I., Serafeim, G. 2014. The impact of corporate sustainability on organizational processes and performance. *Manag. Sci.* 60, 2835–2857.
- Engert, S., Rauter, R., Baumgartner, R. J. 2016. Exploring the integration of corporate sustainability into strategic management: a literature review. *J. Clean. Prod.* 112, 2833–2850.
- Estiningtyas, W. 2015. Asuransi Pertanian Berbasis Indeks Iklim: Opsi Pemberdayaan dan Perlindungan Petani Terhadap Risiko Iklim. *Jurnal Sumberdaya Lahan* Vol. 9 No. 1, 51-64.
- Estiningtyas, W., Boer, R., Las, I., Buono, A., Rakhman, A. 2011. Deliniasi Risiko Iklim dan Evaluasi Model Hubungan Curah Hujan dan Produksi Padi dalam Mendukung Pengembangan Asuransi Indeks Iklim (Climate Index Insurance) Pada Sistem Usahatani Berbasis Padi. *Jurnal Ilmu Pertanian Indonesia*, 198-208.
- Faris, C., Gilbert, B., LeBlanc, B., Ballou, B., Heitger, D. L. 2013. Demystifying Sustainability Risk: Integrating the Triple Bottom Line into an Enterprise Risk Management Program. The Committee of Sponsoring Organizations of the Treadway Commission (COSO).
- Fiscal Risks Management Center of The Ministry of Finance Fiscal Policy Agency. 2014. *Kajian Persiapan Implementasi Asuransi Pertanian Secara Nasional*.
- Giese, Guido, Linda-Eling Lee, Dimitris Melas, Zoltan Nagy, and Laura Nishikawa June. 2018. Foundation of ESG Investing Part 1: How ESG Affects Equity Valuation, Risk and Performance. MSCI.
- Giese, Guido, Linda-Eling Lee, Dimitris Melas, Zoltan Nagy, and Laura Nishikawa June. 2018. Foundation of ESG Investing Part 2: Integrating ESG into Benchmarks. MSCI.
- Giese, Guido, Linda-Eling Lee, Dimitris Melas, Zoltan Nagy, and Laura Nishikawa June. 2018. Foundation of ESG Investing Part 3: Integrating ESG into Passive Portfolio. MSCI.

- Giese, Guido, Linda-Eling Lee, Dimitris Melas, Zoltan Nagy, and Laura Nishikawa June. 2018. Foundation of ESG Investing Part 4: Integrating ESG into Factor Strategies and Active Portfolio. MSCI.
- Gilbert, S., Zhao, L. 2017. The Knowns and Unknowns of China's Green Finance, Contributing Paper for The Sustainable Infrastructure Imperative: Financing for Better Growth and Development. New Climate Economy, London, Washington, DC.
- Global Council. 2015. *ASEAN Insurance Markets*.
- Green Insurance. <https://www.iii.org/article/green-insurance>.
- Hazell, P. B., Pomareda, C., Valdes, A. 1986. Crop Insurance for Agricultural Development: Issues and Experience.
- Herremans, I. M. and Nazari, J. A. 2016. Sustainability reporting driving forces and management control systems. *J. Manag. Account. Res.* 28, 103–124.
- Insurance Working Group of the United Nations Environment Programme Finance Initiative. 2007. Insuring for Sustainability: Why and How the Leaders are Doing It. Inaugural Report.
- Insyafiah and Wardhani, I. 2014. Kajian Persiapan Implementasi Asuransi Pertanian Secara Nasional. Pusat Pengelolaan Risiko Fiskal Badan Kebijakan Fiskal Kementerian Keuangan.
- Jollands, S., Akroyd, C., Sawabe, N. 2015. Core values as a management control in the construction of “sustainable development”. *Qual. Res. Account. Manag.* 12, 127–152.
- Joshi, S., Li, Y. 2016. What is corporate sustainability and how do firms practice it? A management accounting research perspective. *J. Manag. Account. Res.* 28, 1–11.
- Li, Wei, Hu, M. 2014. An overview of the environmental finance policies in China: Retrofitting an Integrated Mechanism for Environmental Management. *Front. Environ. Sci. Eng.* 2014, 8(3), 316-328.
- Mills, E. 2015. Insurers as Partners in Inclusive Green Growth. International Finance Corporation World Bank Group.
- Moraes, Claudio O, Monte, Gabriel C, Antunes, José Américo Pereira. 2016. How does capital regulation react to monetary policy? New evidence on the risk-taking channel. *Economic Modelling* Vol.56, pp. 177-186.
- Munich Re Foundation dan GIZ-RFPI. 2014. *The Landscape of Micro-insurance in Asia and Oceania 2013*.
- NASA. Climate Change: How do We Know? <https://climate.nasa.gov/evidence/>.
- Ng, Artie W. 2018. From sustainability accounting to a green financing system: Institutional legitimacy and market heterogeneity in a global financial centre. *Journal of Cleaner Production* Vol.195. pp. 585–592.
- O'Dwyer, B. 2011. The case of sustainability assurance: constructing a new assurance service. *Contemp. Account. Res.* 28, 1230–1266.
- O'Dwyer, B., Owen, D. L. 2005. Assurance statement practice in environmental, social and sustainability reporting: a critical evaluation. *Br. Account. Rev.* 37, 205–229.
- O'Dwyer, B., Owen, D., Unerman, J. 2011. Seeking legitimacy for new assurance forms: the case of assurance on sustainability reporting. *Account. Organ. Soc.* 36, 31–52.
- Organisasi Perburuhan Internasional. 2008. Konvensi ILO No. 102 Tahun 1952 mengenai (Standar Minimal) Jaminan Sosial. Jakarta.
- Otoritas Jasa Keuangan. 2013. Grand Design Pengembangan Asuransi Mikro Indonesia. Tim Pengembangan Asuransi Mikro Otoritas Jasa Keuangan.
- Otoritas Jasa Keuangan. 2017. Statistik Perasuransian Indonesia 2016.
- Peraturan Menteri Negara Lingkungan Hidup Nomor 18 Tahun 2009 tentang Tata Cara Perizinan Pengelolaan Limbah Bahan Berbahaya dan Beracun.



- Peraturan Otoritas Jasa Keuangan No. 23/POJK.05/2015 tentang Produk Asuransi dan Pemasaran Produk Asuransi.
- Peraturan Otoritas Jasa Keuangan No. 73/POJK.05/2016 tentang Tata Kelola Perusahaan yang Baik Bagi Perusahaan Perasuransian.
- Peraturan Pemerintah Republik Indonesia No. 46 tahun 2017 tentang Instrumen Ekonomi Lingkungan Hidup.
- Perdian, 2014. Climate Change and Crop Insurance: Application of Crop Model. Workshop on Capacity Development on Downscaling Climate Change Projection and Index Base Agricultural Insurance.
- PricewaterhouseCoopers. 2013. Exploring green finance incentives in China. p. 1-71. [http://www.pwccn.com/webmedia/doc/635163938836835335\\_green\\_finance\\_incentives\\_oct2013\\_eng.pdf](http://www.pwccn.com/webmedia/doc/635163938836835335_green_finance_incentives_oct2013_eng.pdf).
- Riswinandi. 2018. Growing Climate Change Risk and How It Manifest for Insurance Markets. Indonesia Financial Service Authority presentation in Tokyo, April 26, 2018. Non-published presentation
- Sloggert, Justin. 2016. A Practical Guide to ESG Integration for Equity Investing.
- Smith, V. H., Glauber W. J. 2012. Agricultural Insurance in Developed Countries: Where Have We Been and Where Are We Going?. Applied Economic Perspectives and Policy 363-390.
- Solheim, E. 2016. Green Finance for Developing Countries: Needs, Concerns and Innovations. www.UNEP.org.
- Taylor, William J and Zilberman, Roy. 2016. Macroprudential regulation, credit spreads and the role of monetary policy. Journal of Financial Stability Vol.26, Pp. 144-158.
- The Consultative Group to Assist the Poor (CGAP). Disaster Risk Insurance to Promote Resilience. Accessed Juni 27, 2018. CGAP (the Consultative Group to Assist the Poor).
- The Geneva Association. 2018. *Climate Change and the Insurance Industry: Taking Action as Risk Managers and Investors*.
- The Insurance Climate Change Initiatives. Global insurance industry statement on Adapting to Climate Change in Developing Countries.
- The Literacy and Financial Inclusion Department of Education And Consumer Protection of The Financial Services Authority (OJK). 2017. *Survey Nasional Literasi dan Inklusi Keuangan 2016*.
- The PSI Global Resilience Project. 2015. Collaborating for Resilience: Partnership that Build Disaster-Resilient Communities and Economies. UNEP Finance Initiative.
- The UNEP Inquiry into the design of a sustainable financial system. 2015. Towards a sustainable financial system in Indonesia. Ulrich Volz, SOAS, University of London and German Development Institute.
- The UNEP Inquiry. 2015. Insurance 2030: harnessing Insurance for Sustainable Development. Inquiry Working Paper.
- Undang-Undang Republik Indonesia No. 19 Tahun 2013 tentang Perlindungan dan Pemberdayaan Petani.
- Undang-Undang Republik Indonesia No. 23 tahun 1997 tentang Pengelolaan Lingkungan Hidup.
- Undang-Undang Republik Indonesia No. 32 Tahun 2009 tentang Perlindungan dan Pengelolaan Lingkungan Hidup.
- Undang-Undang Republik Indonesia No. 40 Tahun 2004 Tentang Sistem Jaminan Sosial Nasional.
- UNEP FI and WBCSD. 2010. Translating ESG into Sustainable Business Value. Genève: UNEP FI and WBCSD.
- UNEP FI. 2012. PSI: Principles for Sustainable Insurance. Genève: UNEP FI.

- UNEP Finance Initiative. 2012. Principles for Sustainable Insurance: A global sustainability framework and initiative of the United Nations Environment Programme Finance Initiative.
- UNEP Financial Initiative. 2012. PSI: Principles for Sustainable Insurance. Genève: United Nation Environment Programme Finance Initiative.
- Wang, Yao and Zhi, Qiang. 2016. The role of green finance in environmental protection: Two aspects of market mechanism and policies. *Energy Procedia* vol. 104, pp. 311 – 316.
- Weber, O. 2014. The financial sector's impact on sustainable development. *J. Sustain. Finance. Invest.* 4, 1–8.
- Weber, O., Scholz, R. W., Michalik, G. 2010. Incorporating sustainability criteria into credit risk management. *Bus. Strategy Environ.* 19, 39-50.
- Wibisana, A. G., and Putri, P. K. 2009. Analisa Law and Economics atas Kompensasi dan Asuransi Lingkungan di Indonesia: Sebuah Kritik atas Kompensasi Tanpa Sistem. *Jurnal Hukum dan Pembangunan Tahun ke-39 No. 4* 531-571.
- World Food Programme dan OXFAM America. 2014. R4 Rural Resilience Initiative. Quarterly Report.
- Zona, Rita, Kevin Roll, and Zora Law. 2014. Sustainable/Green Insurance Products. *Casualty Actuarial Society E-Forum*.